



MIXING

› BLEND WITH CARE

www.pcm.eu

INTRODUCING A BETTER WAY TO MIX

With consumers demanding ever more innovative foods that require expensive ingredients, PCM inline mixing solutions deliver the cost efficiency and safety your operations require.

› OPTIMIZING TOTAL COST OF OWNERSHIP

PCM inline mixers protect the most important asset in your production line: your ingredients. Our solutions reduce loss, preserve texture and never damage ingredients. They handle fragile ingredients with care and accurately distribute solids.

› FOOD SAFETY YOU CAN COUNT ON

Built from the highest quality food-grade materials, PCM inline mixers operate in a closed-circuit configuration. They minimize the risk of product contamination by eliminating the need for an openair, mixing tank. Designed to 3A standards, they are easy to clean and sterilize in place, thereby reducing another potential source of contamination.

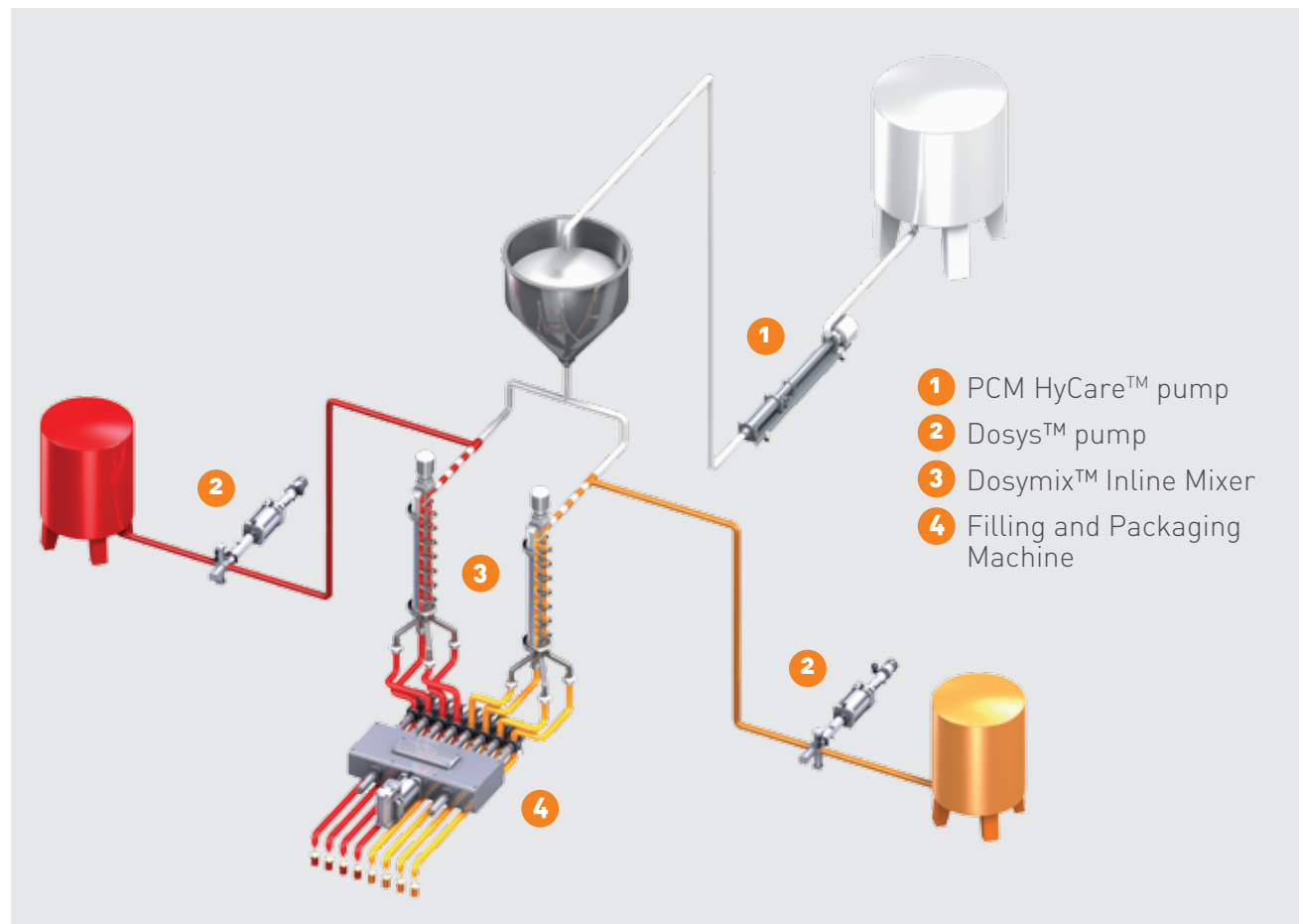

Just-in-time multi pack production flow

CREATING INNOVATION WITH INLINE MIXING

PCM inline mixers give you the freedom to create innovative compositions while protecting costly ingredients. They mix using progressive contact rather than beating, making it possible to blend a wide range of fluids with varying levels of viscosity and solids.

› LESS LOSS

With PCM inline mixers, less product is lost when switching recipes or at the end of a production run. And because they blend using smaller volumes, they are ideal for mixing tasks that require the just-in-time addition of blending time-sensitive ingredients.

› DAMAGE-FREE MIXING

PCM inline mixers produce homogenous blends without altering product or ingredient consistency. This eliminates the use of expensive additives to recover texture. Our mixers are also particularly well suited to handling fragile solids, such as fruits, thanks to the gentle nonshearing mixing action.

› MORE FLEXIBILITY

When your production requires rapid ingredient change, a PCM inline mixer is the answer. You can switch ingredients in mid-production without having to empty the batch tank first. Our inline mixers can also be fitted with multiple outlets for extremely even distribution through multiple filling nozzles.

› COST-EFFICIENT CLEANING

With a PCM inline mixer there is no tank to scrape at the end of a production run, unlike with batch mixing. And the mixer's small internal volume makes it easy to clean with minimal quantities of hot water and chemicals, using your standard CIP/SIP processes.



Dosymix™ multi outlet feeding downstream dosing heads



Low shear screw profile preserves product texture

SYSTEMS

› INLINE STATIC MIXER

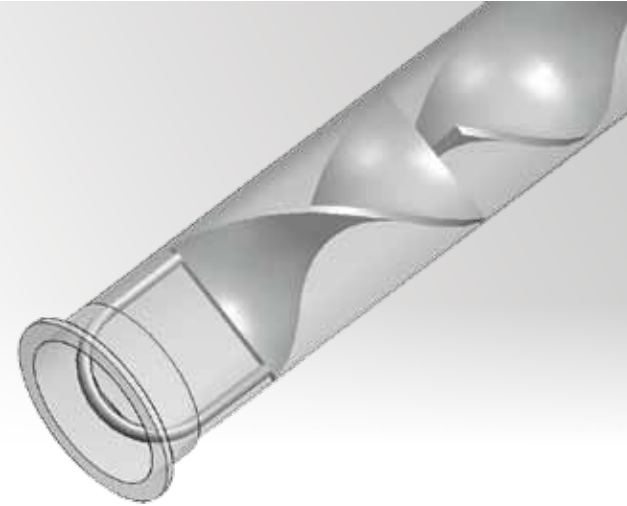

Capacity **up to 35.000 l/h**

Ideal for blending products **with similar viscosity and in similar proportions.**

- **Simple construction:**
Easy process integration
- **Low internal volume:**
Limited product loss
- **No moving parts:**
No special power requirements or wear
- **No spare parts to be replaced:**
Zero maintenance

› INLINE DYNAMIC MIXER: DOSYMIX™

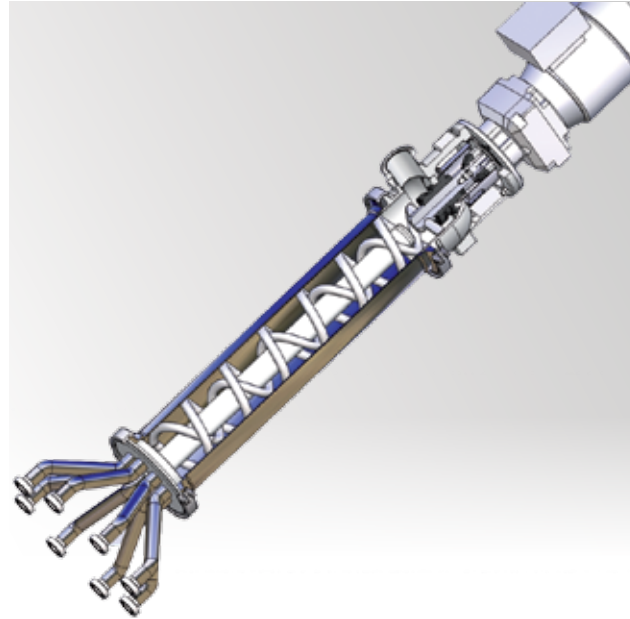

Capacity **up to 5.400 l/h**

Ideal for **fragile and shear sensitive ingredients**, with solids or fibers. For blending products with very different viscosities and/ or proportions, **in pulsating or continuous flow.**

- **Hygienic design:**
3A design – Easy CIP and SIP
- **Low internal volume:**
Limited product loss
- **Multi-outlets:**
Accurate distribution
- **Special screw profiles:**
No-shear, damage-free uniform mixing



› INLINE DYNAMIC MIXER: DOSYMIX™ + PRE-FILLING BUFFER

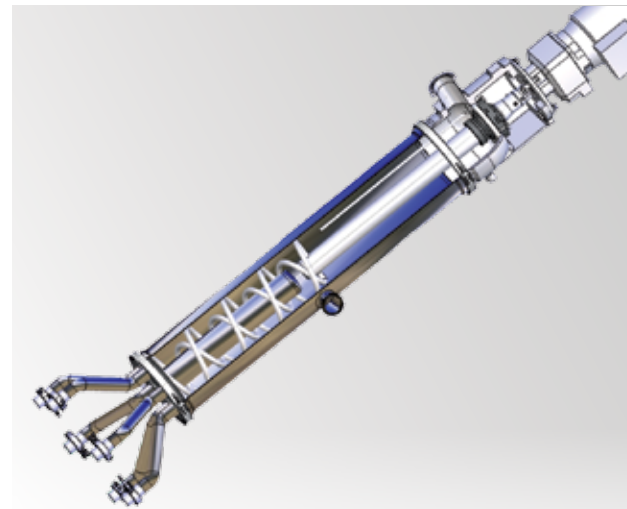

Capacity **up to 5.400 l/h**

Replaces the buffer tank of **the filling machine** and blends just before filling.

- **Space-saving installation:**
Two components in one
- **Faster CIP/SIP:**
Tank-less design
- **Cost-effective upgrade:**
Improves mixing and distribution using existing process
- **Reduced losses:**
Injection of fruit (or other solids) just before the filling machine.



Dairy

- Fruits, pulps and flavor into yogurt
- Ferments, rennet, brine, flavor or fruit into cheese
- Fruit Pulp into Ice cream



Real-world applications: Dairy

Mixing fruit into yogurt is a delicate operation. It is important to maintain the fruit texture while ensuring an even color and fruit distribution. Using Dosymix, our customer is able to produce a high quality mixture, while meeting all these criteria, with full cleaning-inplace capability.

Meat, fish, animal food

- Flavors, color and ingredients into meat preparation



Real-world applications: Petfood

The client was unsatisfied with the performance of its in-house developed mixer, which would clog up regularly due to meat fibers. This would force production to stop while the mixer was dismantled and cleaned.

After replacing it with a Dosymix 2000, the mixing operation now functions smoothly with minimal maintenance. It also produces a high quality, visually appealing product.

Baked goods

- Flavor, nuts into chocolate
- Egg into milk
- Egg whip into cream



Convenience food

- Herbs, seeds into sauces
- Vegetables into soup
- Sauces, water, additives into vegetables (purée or chopped)



AT YOUR SERVICES

We provide a complete range of services that put our expertise to work for you in four key Food industry domains: transfer, dosing, mixing and filling.

› CO-DEVELOPMENT

Our expertise can give you a precious edge in bringing new products to market. By determining the economic and industrial feasibility of a system as early as possible we help you reduce the risk of a costly failure and accelerate the path to reward.

› CONSULTING & TRAINING

To ensure optimum operational efficiency of PCM systems, we provide upstream testing of product compatibility, viscosity and abrasiveness. We bring pumping solutions online faster with start-up assistance. To accelerate knowledge transfer to our customers, our teams provide training services for your staff.

› INTERNATIONAL PARTS DISTRIBUTION

Thanks to our worldwide network of sales offices and distributors, you can obtain genuine PCM spare parts quickly. Using PCM spare parts ensures that PCM products last as long as possible, benefit from warranty protection and maintain their CE conformity until their end of life. We also provide a comprehensive portfolio of maintenance services.

› REPAIRS & UPGRADES

Maintenance can be performed on site or in our facilities. Our technicians can also upgrade existing systems with new technologies.



Dosymix™ assembling at PCM

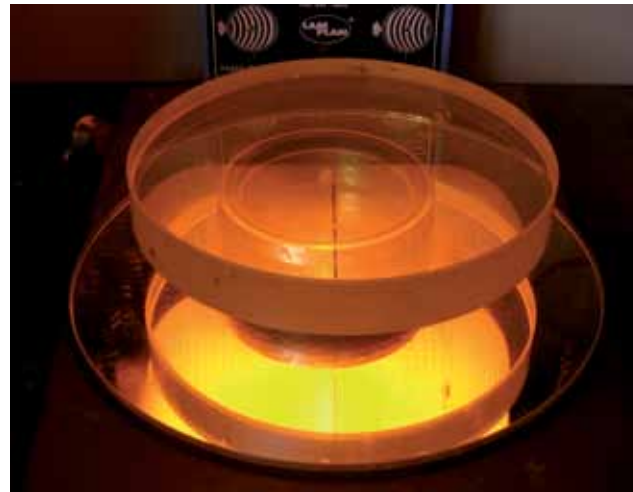

Mechanical seal assessment at PCM

ABOUT PCM



- PCM Group Headquarters
- PCM Regional Headquarters
- PCM Direct sales and services Offices

PCM is one of the world's leading manufacturers of positive displacement pumps and fluid-handling equipment. The company was co-founded in 1932 by the inventor of the Progressing Cavity Pump (PCP), René Moineau.

PCM Food systems enable you to transfer, dose, mix and fill challenging ingredients (including fluids with high viscosity and solids content) with minimal damage.

