

ECOMOINEAU™ C

› THE SHORTEST STAINLESS
STEEL PROGRESSING
CAVITY PUMP

www.pcm.eu



ECOMOINEAU™ C

THE SHORTEST STAINLESS-STEEL PROGRESSING CAVITY PUMP IN THE MARKET

PCM EcoMoineau™ C: *the smart choice for a wide range of applications.*

› MOINEAU™ TECHNOLOGY

The Moineau™ progressing cavity pump technology

- Handles both fragile and viscous products
- High suction and self-priming capabilities
- Constant non-pulsating flow
- Easy to maintain
- Reversible
- Flow rate proportional to running speed

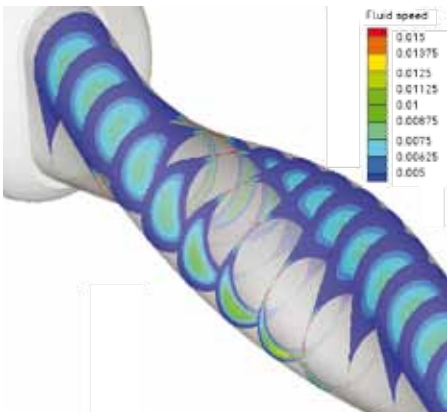

Fluid speed inside the PCP modeling
Simulated in PCM Flow Technology Center

› OPERATION PRINCIPLE

A Moineau™ pump consists of a helical rotor turning inside a helical stator. The stainless steel rotor is machined to a high degree of precision, and the stator is molded in a resilient elastomer.

The geometry and the dimensions of these parts are such that when the rotor is inserted into the stator, a double chain of watertight cavities (honeycombed-shaped) is created. When the rotor turns inside the stator, the honeycomb progresses spirally along the axis of the pump without changing either shape or volume.

This action transfers the product from the pump intake to the pump discharge without degrading the product.



› MAIN FEATURES

The EcoMoineau™ C is the shortest stainless steel Progressing Cavity Pump in the market. This new Eco-designed and compact pump is dedicated for food and industry markets. Very easy and quick to dismantle.

› FOOD ECOMOINEAU™ C



- FDA and European food regulations compliant materials
- Food connections and rinsing ports available
- Single, double and flush mechanical seal

› INDUSTRY ECOMOINEAU™ C



- Available with 3 rotor and 7 stator materials to fit with a wide range of industrial applications
- Multi standard flange connection
- Explosion proof and ATEX constructions available
- Packing gland, single or double mechanical seal

› VERSATILE CONSTRUCTION

Integrated construction

- Cost-effective solution including single bellow mechanical seal (self positioning)
- Shortest and lightest design

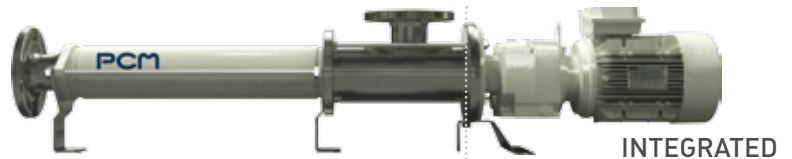

Monobloc or bearing construction

- Five sealing solutions available
- Spacer with improved access to the sealing system
- Rubber deflector: protecting the drive and bearing therefore

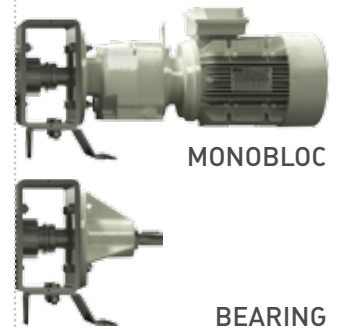

- **Bearing construction:** for more drive options (to adapt to any kind of drive)

› PERFORMANCES

ECOMOINEAU™ C	I SERIES
Maximum Flow rate	
90 m ³ /hr / 396 US GPM	500 m ³ /hr / 2200 US GPM
Maximum pressure	
24 Bar / 350 PSI	45 Bar / 650 PSI - 200 Bar / 2900 PSI upon request
Maximum temperature in continuous operation	
120°C / 248°F	120°C / 248°F

Figures are given as a general guide. For higher values, please contact us.

ADVANTAGES

SPACE SAVING

42% shorter - 57% lighter

Its revolutionary design combines the legendary performance and reliability of PCM Progressing Cavity Pump technology with a highly modular, eco-friendly design. The EcoMoineau™ C pump requires less space for installation which reduces costs and facilitates its integration.

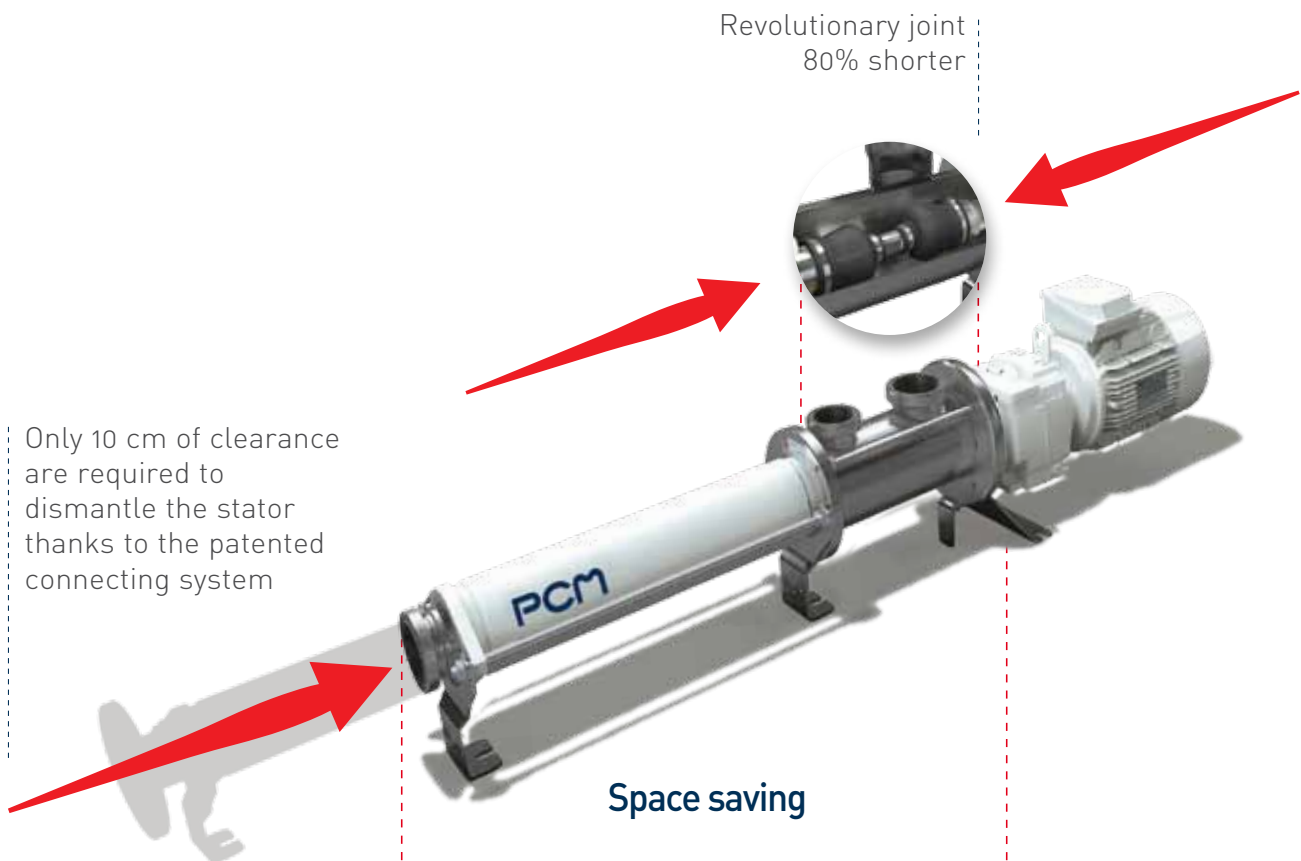

ECODESIGN PUMP

10% less power consumption

The EcoMoineau™ C pump is lighter (less raw materials) and uses 10% less power than most Progressing Cavity Pump's on the market. The energy used to manufacture, transport and operate the EcoMoineau™ C pump is therefore optimized.

» EASY & QUICK DISMANTLING

23% maintenance time saving

The EcoMoineau™ C pump is made with fewer parts compared to competitors models. This new stainless steel pump has a multiple of design features that make installation, operation and servicing easier than ever before.

For example:

- The seal can be changed by simply disconnecting the drive.
- The shaft line (rotor, coupling rod, driving shaft) can be removed without disconnecting the pipes.
- The integrated version comes with a smaller diameter, self-positioning mechanical seal.
- The patented connecting rod has fewer parts and can be supplied in a complete shaft line as one sparepart in order to reduce maintenance downtime.

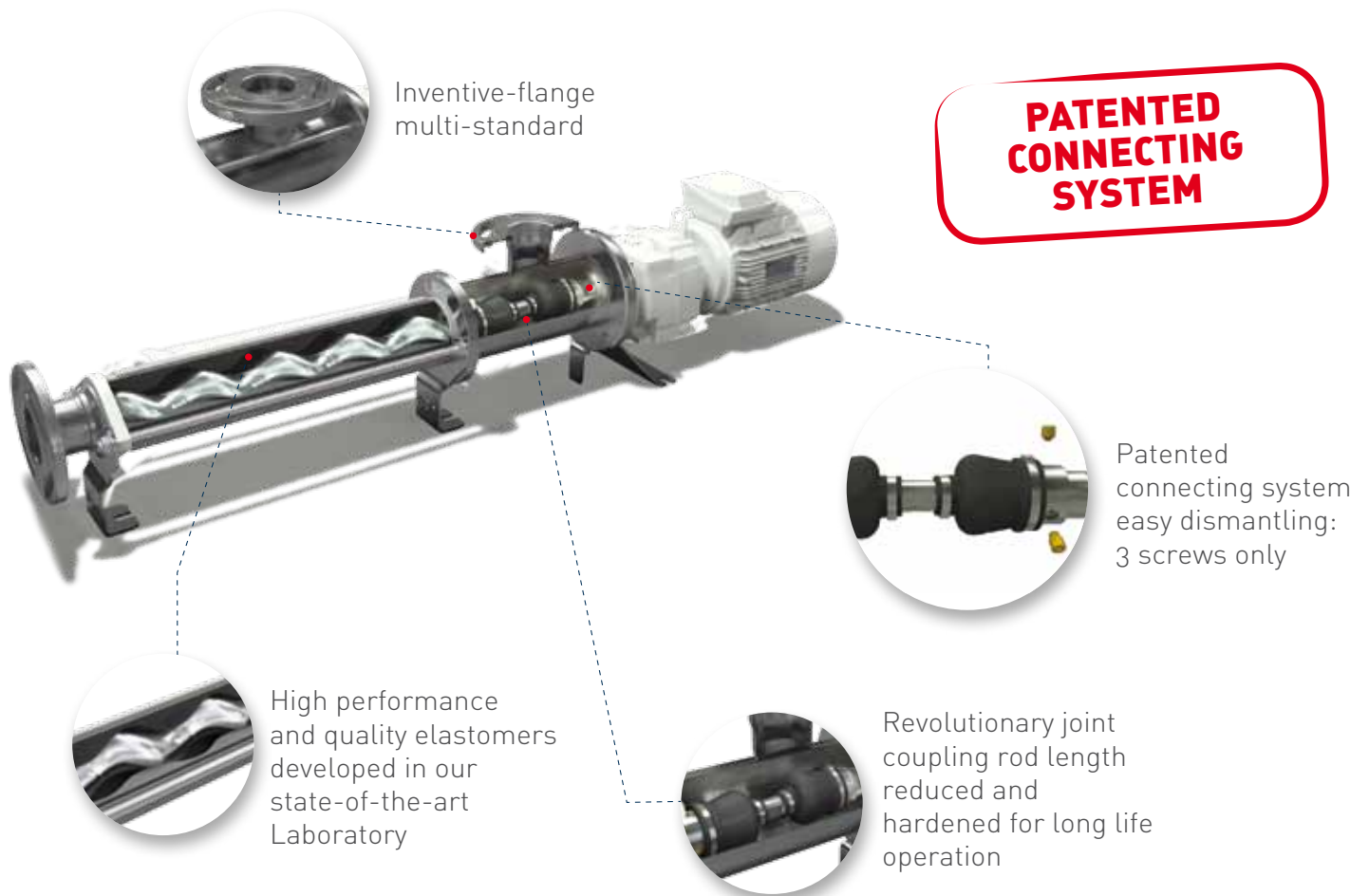

FOOD ECOMOINEAU™ C

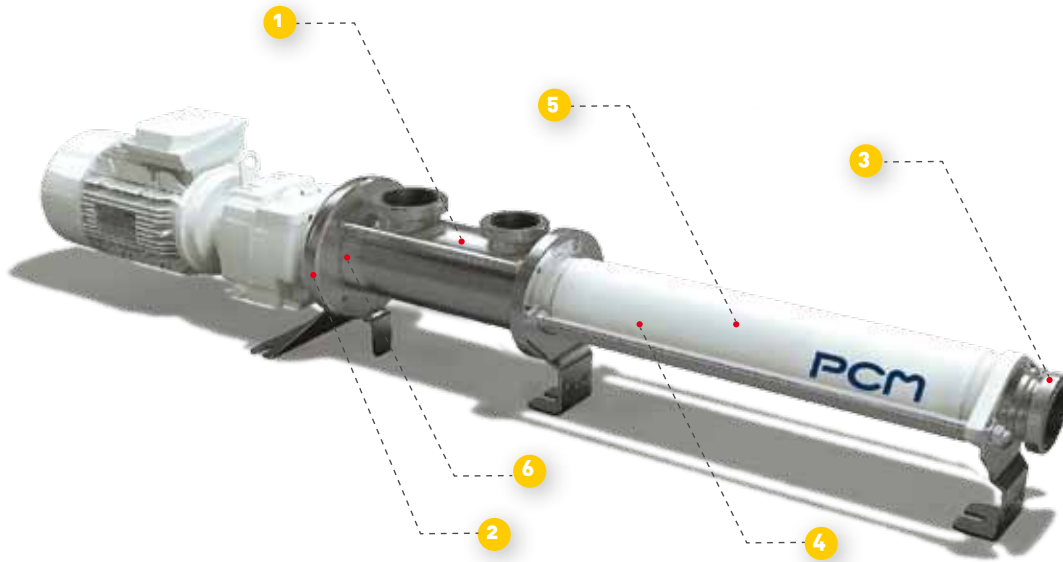

CONSTRUCTION

1 Body	2 Construction	3 Connections	4 Stator	5 Rotor	6 Sealing
Stainless steel 316L	Integrated construction	SMS	NBR white (Food EU)	Duplex Stainless steel 329LN (food or corrosion)	Bellow mechanical seal - Single carbide / carbide FPM FDA
Options	Options	Options	Options	Options	Options
Stainless steel 316L body with rinsing ports on top	Monobloc construction	Clamp	FKM white (Food FDA)	Stainless Steel 420	Mechanical seal - Single stainless steel/ carbon EPDM FDA (flush possible)
	Bearing construction	Macon	NBR (USP)		Mechanical seal - Single carbide / carbide EPDM FDA (flush possible)
		DIN Food			Cartridge mechanical seal - Double carbide / carbide - carbon / carbide FPM FDA (with flush)
		Flange ISO/DIN/ANSI			

INDUSTRY ECOMOINEAU™ C



CONSTRUCTION

1	2	3	4	5	6
Body	Construction	Connections	Stator	Rotor	Sealing
Stainless steel 316L	Integrated construction	ISO/DIN/ANSI	NBR	Stainless steel 420	Bellow mechanical seal-Single carbide/carbide FPM
	Options		Options	Options	Options
	Monobloc construction		EPDM	Duplex stainless steel 329LN (food or corrosion)	Mechanical seal-Single stainless steel/ carbon EPDM FDA (flush possible)
	Bearing construction		FKM	Hard Chromed stainless steel 420 (abrasion)	Mechanical seal-Single carbide/carbide EPDM FDA (flush possible)
			CR		Cartridge mechanical seal-Double carbide/carbide - Carbon/carbide FPM FDA (flush possible)
			IR		Gland Packing (no flush)
			NR		Gland Packing (with flush)
			CSM		

INDUSTRIES AND APPLICATIONS



› CHEMICALS

Polymer, sizing, resins and hardeners, acids and alkalines, oils, water based paint...



› MINERALS

Slurries, explosive preparation, coloring agent, miscellaneous agents (grinding)...



› PAPER

Coating colour, dyes, starch, kaolin, talc, bentonite, calcium carbonate, titanium dioxide...



› MEAT INDUSTRY

Pet food, fatty products, grease, fat or oil (tallow, lard, colza, olive, palm, ...) enzymes...



› SUGAR INDUSTRY

Molasses, glucose, saccharose, syrup, starch, honey, liquor, ...



› CONVENIENCE FOOD

Puree, soups, cooked food, seasoning (chilli, ketchups, soya sauces, ...)



› BEVERAGE INDUSTRY

Juices, wine-making, ingredients, additives, beers, syrups, ...