

# Xstream and green PUMPING



The new PCM **Delasco™ DX** series  
**DX65 - DX80 - DX100**



## MOVING CONCENTRATED FLUIDS TO CUT DOWN YOUR PROCESSING COST

**Water is precious.** Saving water has become paramount in industrial processes. Scarcity and costs trigger the need to convey ever more concentrated fluids.

PCM Peristaltic DX series can transfer highly concentrated fluids eliminating the need to add water to enable pumping. This allows for greater water and associated cost savings by minimizing infrastructures and reducing filtration costs.



## CUT DOWN MAINTENANCE TIME AND COST

By nature peristaltic pumps are easy to maintain thanks to their seal-less construction, and as the only wetted part is the hose. PCM substantially improved the technology with an optimized hose life time, a smart quick release system which eases the hose change and the internal bearing to cut drive related maintenance.



## DESIGNED TO LAST IN THE TOUGHEST ENVIRONMENTS

To provide robust and durable efficiency, PCM Delasco™ DX has been designed to sustain both internal and external wear factors, whether they are chemical or mechanical



## PCM DELASCO™ PERISTALTIC PUMPS

The ideal choice to reduce maintenance costs

### › Principle of Delasco™ technology

The peristaltic pumping principle is based on the capacity of a soft elastomer hose to accept a deformation and subsequently recover its initial shape. Peristaltic pumps are provided with high pressure hoses, covering a wide range of applications which need versatility and flexibility.

The flow rate is proportional to the pump speed, easily adjustable via energy efficient variable speed drive.

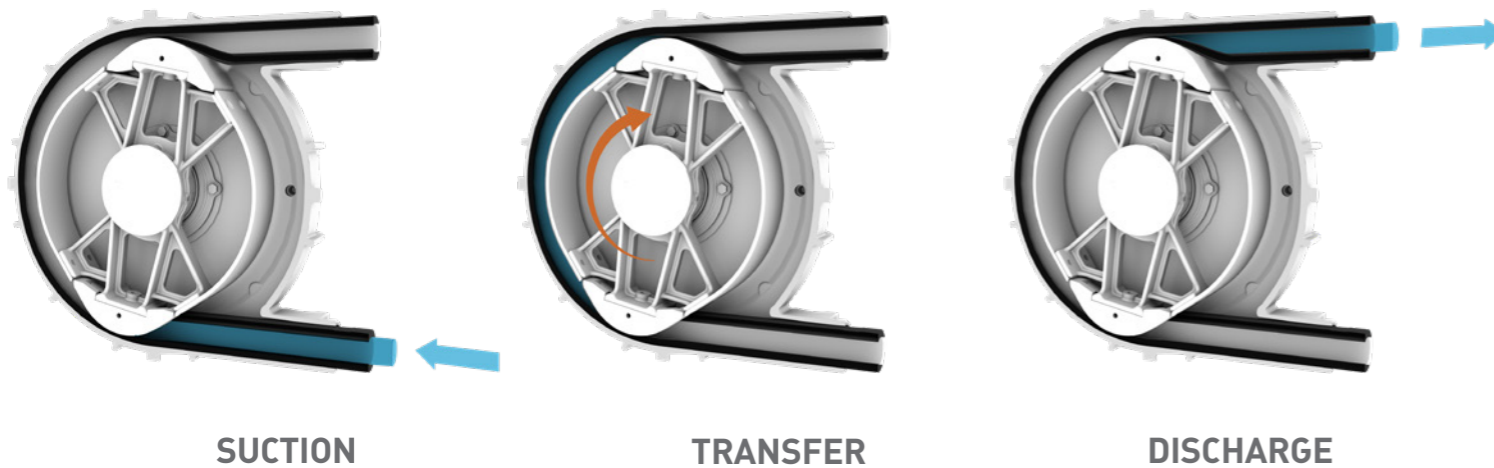

## PERISTALTIC PUMPS BENEFITS

### › One pump for all fluids

- Abrasive and high solids content slurries up to 80%
- High Density
- Corrosive
- Shear sensitive
- Viscous
- Multiphase/gaseous
- Crystalizing

### › Optimised OPEX for tough applications

- Only one wearing part: the hose;
- Easy on-site maintenance and short downtimes thanks to a unique hose quick release allowing hose change in only a few minutes
- Seal-less design: no expensive sealing to replace and no associated seal-water flushing costs
- Low energy requirements thanks to the inherent low running speed

### › One pump for all tasks

- Transfer, dosing, emptying
- Self-priming
- High suction lift
- Reversible
- Can run-dry and needs no ancillary protection equipment

### › Disaster / contamination proof technology

- Seal-less
- Only one wearing and wetted part: the hose





# PCM DELASCO™ DX

DX65 - DX80 - DX100 series

## High quality hoses

High quality hoses from a premium elastomer pump manufacturer.

Because we know elastomers play a critical role in our various technology products, we developed a unique elastomer expertise within a dedicated R&D team.

PCM Delasco™ DX series hoses are available in natural rubber and EPDM. Made of high quality rubber and reinforcement layers, they are precision machined to meet perfect even-wall thickness and provide long service life.

- **NR:** abrasive, clay, lime milk
- **EPDM:** corrosive, acids

## Robust design

- Shock resistant heavy cast X-cover design.
- Improved ergonomic design with accessories connected at the pump back.



## Disaster and contamination proof design

100% leak proof body to hold the fluid in case of hose rupture:

- Double seal and bearing barrier
- Integrated buffer zone
- Sheath around connection

## Compact footprint

Thanks to the integrated bearing design PCM Delasco™ DX features one of the smallest footprints on the market

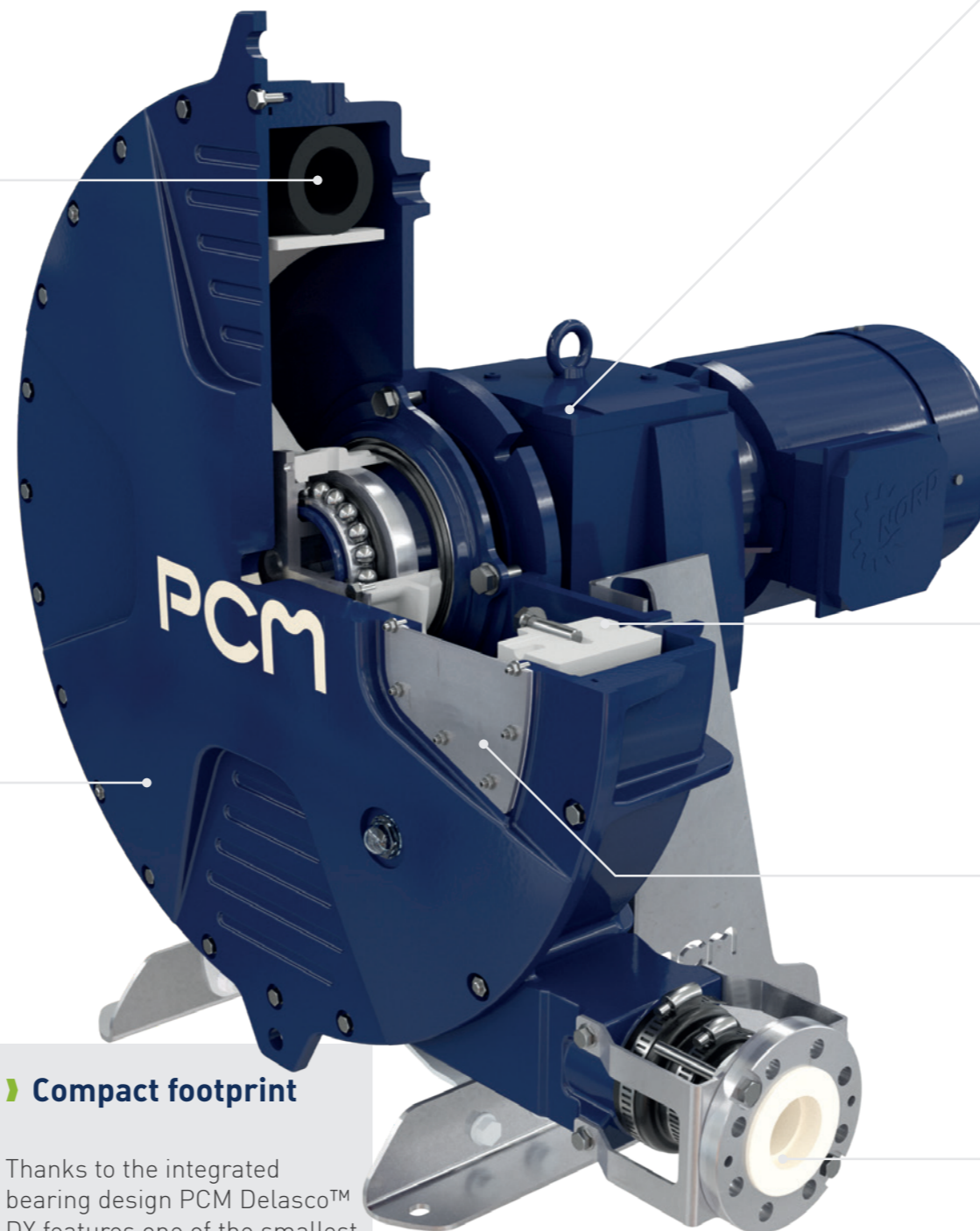

## Plug-in drive system and long lasting drive thanks to the integrated bearing technology.

The integrated bearing eliminates load on gear motor bearings and favours heat dissipation; bare-shaft assembly for easy coupling with major motor manufacturers. No drive alignment is required.



## Progressive hose compression to extend hose life

Thanks to our unique lemon shaped rotor and deflector design

## Customized shimming for an even and optimized hose compression

To grant a perfect hose compression and long service life, every PCM Delasco™ DX is individually shimmed to perfectly match your pumping conditions

## Stainless Steel hatch

- Easy shoe shimming adjustment to accommodate new conditions
- Inspection and oil refilling port
- Made of stainless steel to comply with ATEX

## Easy connection quick release system

Our simple yet ingenious pull-out system allows fast connection removal and easy hose change even after hours of operations on sticky products.

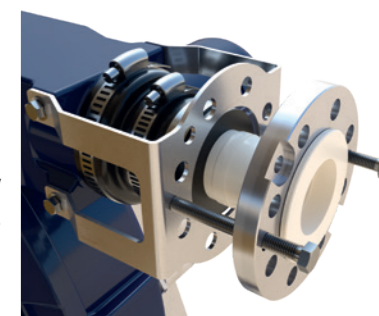

## CURVES

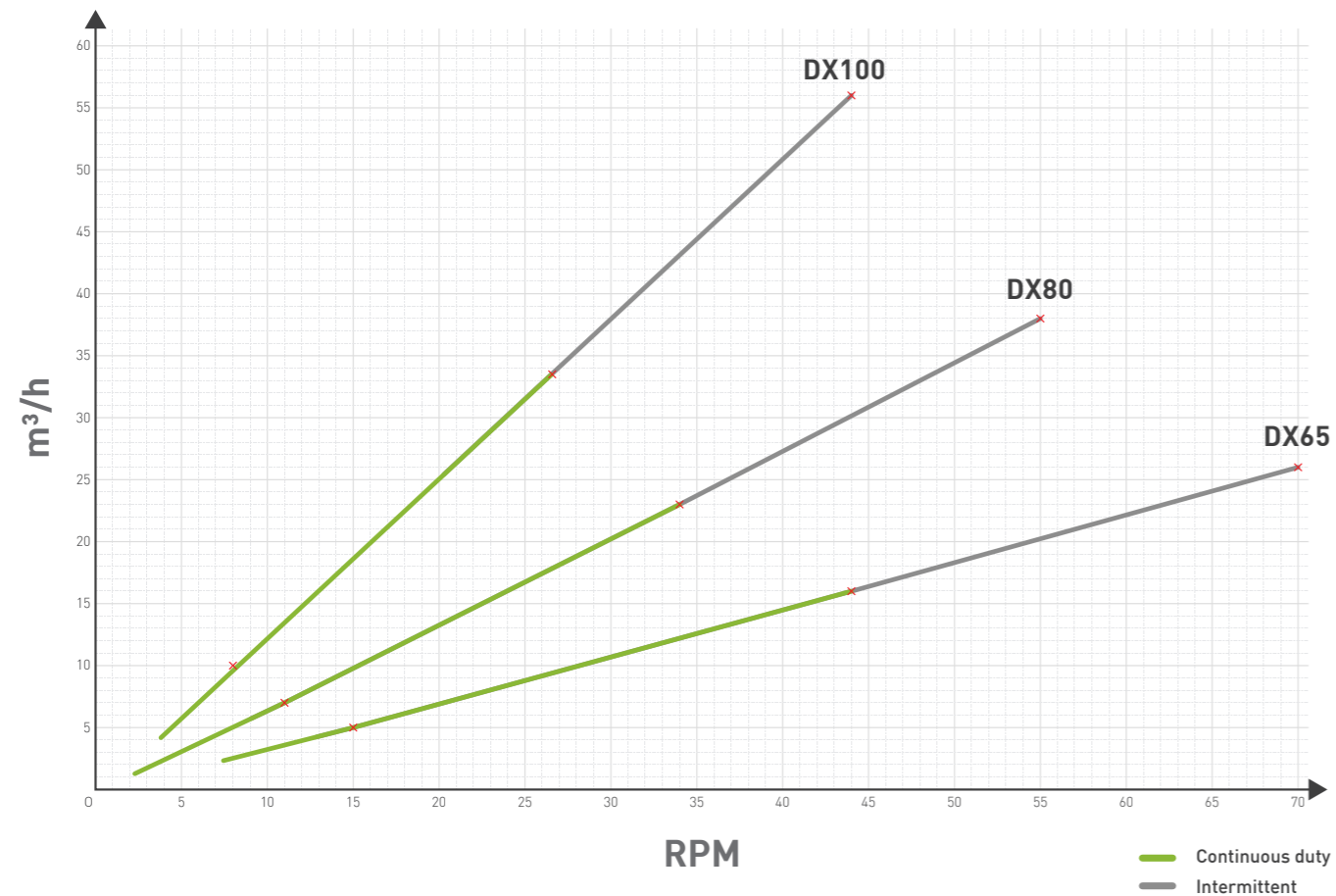

## DUPLEX READY DESIGN

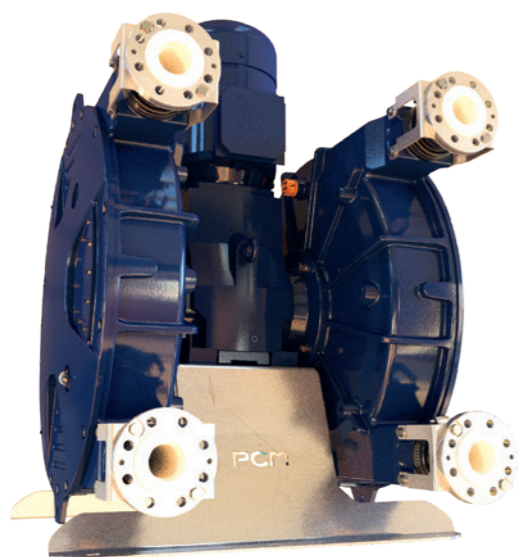

### Large flow rates up to 100 m³/h

PCM Delasco™ DX series is also available in duplex configuration. With two pump heads and one single drive, the PCM Delasco™ DX Duplex series allows to double the flow rate of a single pump with the benefit of a reduced footprint less pulsations and less maintenance costs.

## GENERAL DIMENSIONS

mm [in]	DX65	DX80	DX100
A	1140 [43.70]	1464 [57.64]	1569 [61.77]
B	205 [8.07]	412 [16.22]	332 [13.07]
C	740 [29.13]	864 [34.02]	1024 [40.31]
E	505 [19.88]	600 [23.62]	663 [26.10]
F	622 [24.49]	732 [28.82]	858 [33.77]
G	362 [14.25]	382 [15.04]	508 [20]
H	575 [22.64]	844 [33.23]	
KxK1	18 x 23 [0.71 x 0.91]	26 x 35 [1.02 x 1.38]	

mm [in]	DX65	DX80	DX100
L	520 [20.47]	700 [27.56]	
M	600 [23.62]	780 [30.71]	
N	660 [25.98]	1025 [40.35]	
P	585 [23.03]	810 [31.88]	
Q	110 [4.35]	52 [2.05]	35 [1.37]
R	38 [1.48]	150 [5.90]	
Kg [Lbs]	397 [875]	680 [1469]	960 [2116]

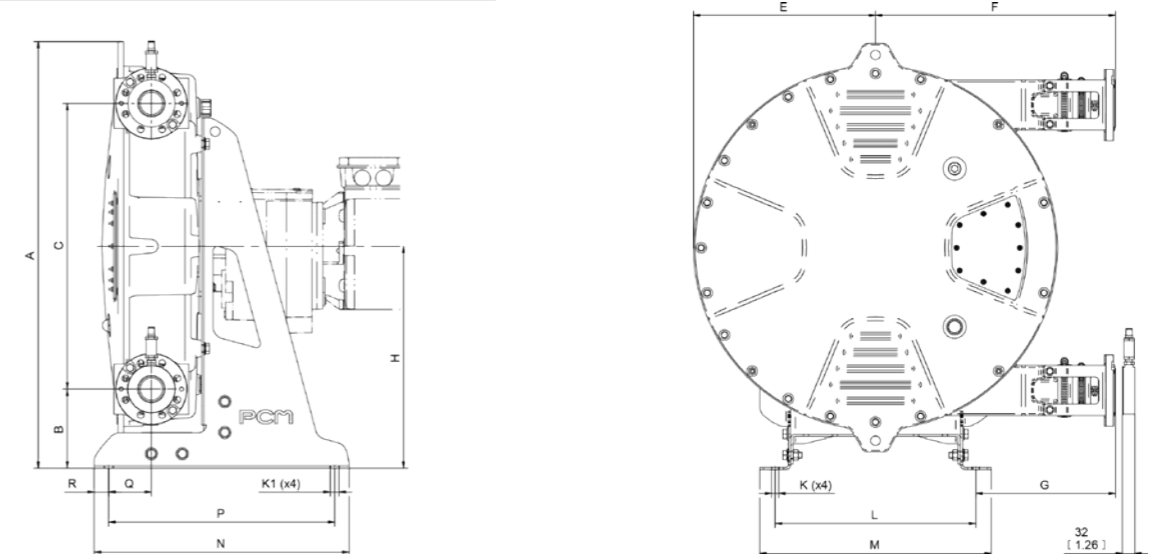

## ACCESSORIES

### Hose leak detector

Stops the pump in case of hose rupture via float sensor.

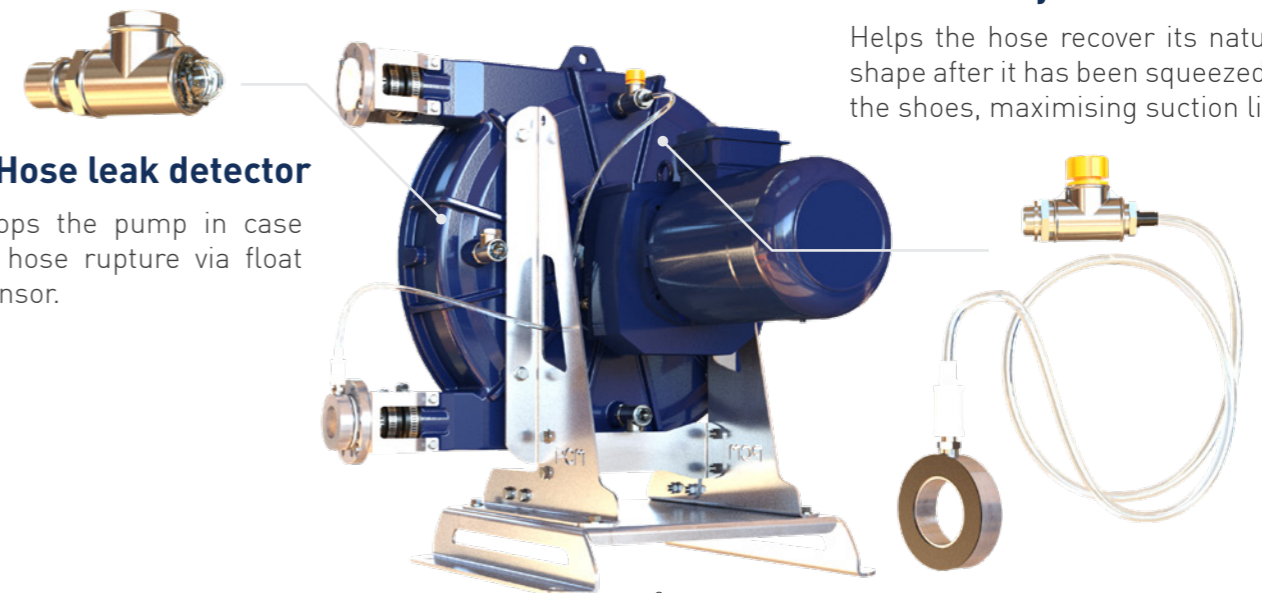

### Vacuum system

Helps the hose recover its natural shape after it has been squeezed by the shoes, maximising suction lift.



## ABRASIVE SLURRIES HIGH DENSITY HIGH SOLIDS CONTENT LESS WATER

Abrasive slurries are among the most challenging fluids to pump. Besides abrasion, their thick, corrosive and high solids content nature put heavy stress on most pumps wetted parts entailing excessive wear, high maintenance costs and costly shutdowns.

Pump selection is therefore critical to ensure constant productivity and reduced operational costs.

PCM Delasco™ DX series allow you to gain control on both process and costs.

- High Solids Content capabilities up to 80% eliminate the need to dilute slurries, directly translating into great savings on water and subsequent filtration costs and infrastructures
- Easy control of the flow rate by simply acting on the pump speed with no compromise on pump efficiency or fluids density
- Pump operation and efficiency are not affected by variations in solids content, viscosity, or pressure
- Rugged design for long service life in the toughest environments. The only wearing part is the hose. Made of high quality abrasion resistant elastomer it provides for thousands of working hours.



### THICKENER UNDERFLOW / SLURRY

Underflow recoveries from high rate or paste thickener are density sensitive processes. PCM Delasco™ DX series ability to move abrasive and high solids content slurries enable great control of fluids density in the thickener while greatly reducing water consumption and related costs.

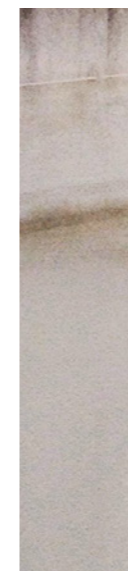

### LIME MILK

Lime milk dosing to restore pH in Acid Mine Drainage or in Waste Water Treatment applications entails accurate metering of viscous and abrasive fluids. With high suction lift and no valves to clog, PCM Delasco™ DX series ensure free fluid passage and long-term reliability.



### GROUTING

Grouting pumps used in tunnel boring machines call for reliable and heavy-duty pumps. The sturdy construction of PCM Delasco™ DX series is well-suited for operating in tough environments and brings maintenance costs to a minimum for pumping abrasive mortars or bentonite slurries.





## VISCOUS SHEAR SENSITIVE FRAGILE PARTICLES

As the shoes compress the hose and propel the fluids forward, the perfect compression and recovery of the hose induces a powerful suction lift while also preventing backflow. The absence of backflow coupled with the low inherent working speed of PCM Delasco™ DX series provides a gentle pumping action, preserving the texture of the most fragile, shear-sensitive and viscous fluids.

Upon hose recovery a strong vacuum draws the fluids into the pump hose; contained between the two shoes, large particles\* can therefore also be transferred with minimal damage and flow smoothly with no risk of clogging valves or turning the pump into a filter.

(\*Soft particles with sizes up to the hose bore diameter and hard particles up to a third of the hose bore diameter)

## FLOCCULANTS

The gentle pumping action of PCM Delasco™ DX series makes them ideal for the most fragile, shear sensitive flocculants. By preserving flocculants texture, their consumption can be reduced and minimize your costs while it provides high settling rates in thickeners.

## BIOMASS

Biomass processes often create challenging situations ranging from chemical attack, varying pumping condition or solids handling. PCM Delasco™ DX series have proven highly efficient for moving materials with varying consistencies or containing large particles.

## WHOLE PIECES

PCM DX series pumping principle allows the transfer of soft and hard particles such as algae used to produce energy, or wood chips in the Pulp and Paper industry. Particles are conveyed with minimal damage while the free passage within the rubber hose ensures trouble-free uptimes.



## DOSING OF CORROSIVE & GASEOUS FLUIDS AIR ISSUES DRY RUNNING

Unlike most other pump technologies, the pumped fluids only make contact with one single part: the inner wall of the hose. The absence of metallic parts makes PCM Delasco™ DX series ideal for dosing corrosive chemicals with minimal maintenance costs.

Entrained air can cause air sensitive or air intolerant pumps to generate high maintenance costs as a result of hammering vibrations or even lead to entire process shut down in case of air-locked impellers, while PCM Delasco™ DX series convey the entrained air transparently providing you with constant productivity.

Further to preventing leaks to the environment, PCM Delasco™ DX series seal-less design also means there is no air ingress likely to contaminate the pumped fluids.

### SODIUM HYPOCHLORITE

Sodium hypochlorite is commonly used across a wide variety of industries. Its high pH level and its off-gassing tendency often provoke pumping issues. PCM Delasco™ DX series can convey the most chemically aggressive fluids through its elastomeric hose while providing trouble free conditions with entrapped air.

### ACIDS

Highly corrosive fluids such as sulphuric or hydrochloric acids require chemical resistant pumps to ensure constant productivity. With PCM Delasco™ DX series, corrosive fluids are only in contact with a chemically inert elastomer hose. In addition, the seal-less design also prevents spillage and environment contamination.

### CERAMIC / PAINT

PCM Delasco™ DX series seal-less design eliminates the risk of air ingress during operations. They are ideal for dosing air-sensitive fluids such as those found in the Ceramic industry or for recirculating paints that cannot tolerate air contamination.



 X-stream and green  
PUMPING



B-000330 -Sept. 2017 - Index A - Non contractual pictures

**PCM**

keep it moving

[www.pcm.eu](http://www.pcm.eu)

Follow us:    